



South African Council
for the Architectural Profession

51 Wessel Road, Right Wing,
Rivonia, Sandton, 2128

P.O. Box 1500, Rivonia, 2128

Tel: 011 479 5000 | Fax: 011 479 5100

Email: info@sacapsa.com
Web: www.sacapsa.com

SOUTH AFRICAN COUNCIL FOR THE ARCHITECTURAL PROFESSION

Professional Practice Examination May 2025

Paper 1

- Candidates are required to answer **ALL** the questions.
- Questions must be answered in **SEQUENCE**. Ensure that your answers are clearly **NUMBERED**.
- This is a **CLOSED BOOK** paper. No notes, supplementary documents or online referencing is permitted.
- All answers must be **in your OWN words** where appropriate.
- Where answers are duplicated between candidates, plagiarised, or copied, **ZERO** marks will be granted.
- Take note that duplicated, plagiarised and/or copied answers may be subject to further investigation, penalties and/or disciplinary action.
- Total marks for paper one – **150 marks**
- Pass mark – a minimum of **50%** in each of the two papers
- Time allocation – **3 hours**

QUESTION 1 – THE ACT & DEFINITIONS + TRUTH STATEMENTS 21 marks

1.1	Which council encompasses the professions found between Act 44 and 49?	(2)
1.2	Professional Bodies under the South African Constitution are intended to primarily protect which members of society?	(2)
1.3	Explain the concept of IDoW as per Clause 26(2)	(3)
1.4	State the names of both of the latest categories of registration:	(4)



South African Council
for the Architectural Profession

51 Wessel Road, Right Wing,
Rivonia, Sandton, 2128

P.O. Box 1500, Rivonia, 2128

Tel: 011 479 5000 | Fax: 011 479 5100

Email: info@sacapsa.com
Web: www.sacapsa.com

In relation to the Act governing the Architectural Profession, state whether the following are **True** or **False**.

1.5	The council must, in consultation with the voluntary associations, formulate recommendations with regard to the principles referred to in section 4(k)(v) of the Council for the Built Environment Act, 2000.	(2)
1.6	The council must annually, after consultation with the voluntary associations, determine guideline professional fees and publish those fees in the Gazette.	(2)
1.7	The CBE may review the guideline professional fees published by the council, and refer the fees back to the parliament for reconsideration	(2)
1.8	If the council, after review by the CBE of the guideline professional fees, is aggrieved about that review, it may refer the matter to the Registrar for a final decision.	(2)
1.9	Any person who is aggrieved by the guideline professional fees published in terms of subsection (2), may bring the matter to the attention of the CBE within 30 days from the date of such publication	(2)



QUESTION 2 – MIXED MULTIPLE CHOICE QUESTIONS

20 marks

Select the correct answer to the following questions by providing only the corresponding letter(s).

2.1	Choose the option below which best describes what a registered professional according to the Code of Conduct.		(4)
	Select ONE (1) from the following list		
	A	The overriding objectives for the Code of Conduct is to strive for excellence in the Architectural Profession, to protect the environment against unsound architectural practices and the delivery of services to the public with due care, skill, diligence and integrity, applying all relevant knowledge in the process.	
	B	The overriding objectives for the Code of Conduct is to strive for excellence in the Architectural Profession and ensure the delivery of services to the public with due care, skill and diligence applying all relevant knowledge in the process.	
	C	The overriding objectives for the Code of Conduct is to strive for excellence for the public in service delivery applying all relevant knowledge in the process.	
2.2	According to the Act, what is the CORRECT term used to refer to the person under whose name a practice is registered in?		(2)
	Select ONE (1) from the following list (2 marks)		
	A	Associate	
	B	Member	
	C	Partner	
	D	Owner	
E	Principal		
2.3	According to the Act, when acting in one's professional capacity, which term should appear at the bottom of credentials in an email or letter?		(3)
	Select ONE (1) from the following list		
	A	Practitioner – provided that one is actively working in the field on an on-going basis	
	B	Professional - provided that the professional is registered and has maintained their license through CPD activities	
	C	Member - provided that the professional owns the business and that the professional is up to date on their CPD points	
D	Designer – provided that the work is of an architectural nature and relates to the design of structures		



E	Consultant – provided that there is a contract in place which defines the role of the consultant in relationship to the party being sent the mail	
2.4		
	Provide the definition of 'complaint' as provided in the SACAP rules for investigations and disciplinary tribunal hearings.	(3)
	Select ONE (1) from the following list	
A	A query received by the council which denotes a registered professional who has not performed their duties with due care, skill, diligence and integrity, and neither has the accused applied all relevant knowledge in the process.	
B	Improper conduct performed by a registered person in terms of the Act and SACAP's Code of Ethics	
C	A message received which speculates that according to contractual requirements, an individual has broken in the Code of Ethics established by SAIA.	
D	All of the above	
2.5		
	On receipt of a complaint of improper conduct of a registered professional, the SACAP Registrar must refer the matter to which body?	(3)
	Select ONE (1) from the following list (2 marks)	
A	The Complaints Committee	
B	The Social and Ethics Committee	
C	The Code of Conduct Committee	
D	The Investigating Committee	
2.6		
	Which of the following would constitute a breach of the Code of Conduct?	(5)
	Select FIVE (5) from the following list	
A	When signing the work of another professional who is not the bona fide author	
B	When a professional undertakes work within their scope in their Category of Registration	
C	When a professional has not made appropriate arrangements for the fulfilment of professional obligations in the event of incapacity or absence from work	
D	When a candidate technologist supervises the work of a candidate draughtsperson	
E	When a Candidate Technologist promotes themselves as a Professional Technologist	
F	When a building plan or document has been prepared under their direct supervision of a professional	
G	When a registered principal who practices architecture in any form does not register it with the Council within 30 (thirty) days of commencing operation officially	
H	When registered professionals take all reasonable measures to the best of their knowledge/expertise to minimise any adverse impact on the environment	



South African Council
for the Architectural Profession

51 Wessel Road, Right Wing,
Rivonia, Sandton, 2128

P.O. Box 1500, Rivonia, 2128

Tel: 011 479 5000 | Fax: 011 479 5100

Email: info@sacapsa.com
Web: www.sacapsa.com

I	When a foreign architectural person practises architecture in South Africa after they have applied and have been granted registration by Council for the duration of the specific contract	

QUESTION 3 – FEE CALCULATION WITHIN TRIBAL AUTHORITY

35 marks

Mr & Mrs Zuma, have a 1 hectare / 10 000 square meter plot at Lion Park, in Tribal Authority, KZN. They require you to provide a quote/fee proposal for the design of their new retirement farm homestead.

They plan to build a low complexity Single Story home with a pool, and a Rondavel with a budget of R2,500,000.00 for construction. (Excluding VAT and professional fees).

The Clients have also stated that there will not be any applicable municipal procedures for this area as it falls outside of the Municipal Jurisdiction, namely Tribal Authority, and so they would like to know if that fact would subsequently warrant them any discounts, due to the exclusion of some services.

They do however require full compliance for their buildings as per building regulations, as this is a prerequisite for their home insurance and bank loan.

3.1 Before work has commenced, the client has enquired about discounts and insists that the fees be negotiated. You were called in to discuss a method to tackle the situation. Answer the following questions on the situation.

3.1.1.	Is there a discount that could be credited to your client? If so what stage of the project would be the discounted amount be?	(3)
--------	---	-----

3.1.2.	The Client notifies you that have acquired another portion of land within the same Tribal Area. They have asked your advise as to which municipal	(3)
--------	---	-----



South African Council
for the Architectural Profession

51 Wessel Road, Right Wing,
Rivonia, Sandton, 2128

P.O. Box 1500, Rivonia, 2128

Tel: 011 479 5000 | Fax: 011 479 5100

Email: info@sacapsa.com
Web: www.sacapsa.com

	department should they inquire in order to obtain requirements for constructing a petrol station on their land. Support your answer	
--	---	--

Given the circumstances of the exclusion of municipal submission procedures, the Client has requested that you provide your Time Based Calculation fee proposal for your services from The budget for the project is R 2 500 000.00.

3.2.	<p>Calculate Time Based Fees for your services from Stage 1 to Stage 4. Your team is inclusive of 2 x Registered Professionals and 1 x Staff Supporting Architectural Work. Using Method 2 in your steps of calculation, you are to:</p> <ul style="list-style-type: none"> Determine the Hourly Rate as determined by SACAP Include VAT Determine the total time-based cost <p>(8 marks)</p> <p>Utilise the given Table below with information for the project team. The hourly Rates Table has also been given to you.</p>	(8)
------	--	-----

Project Team Table

PERSON	POSITION IN COMPANY	DESCRIPTION	MONTHLY SALARY	ESTIMATED HOURS
NM	Professional Senior Technologist	Associates & Managers	R50 000.00	40
YP	Professional Architectural Technologist	Registered Prof Arch carrying direct responsibility for activities related to a project	R 28 000.00	120
JS	Admin & Office Manager	Staff performing work under direction & control to support architectural office	R18 000.00	20



South African Council
for the Architectural Profession

📍 51 Wessel Road, Right Wing,
Rivonia, Sandton, 2128

📮 P.O. Box 1500, Rivonia, 2128

📞 Tel: 011 479 5000 | Fax: 011 479 5100

📧 Email: info@sacapsa.com
🌐 Web: www.sacapsa.com

Hourly Rates Table





South African Council
for the Architectural Profession

51 Wessel Road, Right Wing,
Rivonia, Sandton, 2128

P.O. Box 1500, Rivonia, 2128

Tel: 011 479 5000 | Fax: 011 479 5100

Email: info@sacapsa.com
Web: www.sacapsa.com

Principal / Staff Category	Experience/ Context	Work	Rate Per Hour (excluding VAT)	Rate Per Hour (excluding VAT)	Rate Per Hour (excluding VAT)
			Method 1 - Gross Annual Remuneration	Method 2 - Guideline Rate Calculated by SACAP	Method 3 - DPSA Hourly Fee Rates for Consultants
1. Principals	Specialist		22.5% per R100.00 or part thereof of total annual cost of employment	R3 149	Commensurate with Level 14, 15 and 16 salary bands
	>10 years' experience		20% per R 100.00 or part thereof of total annual cost of employment	R2 531	Commensurate with Level 14 and 15 salary bands
	<10 years' experience		18.5% per R100.00 or part thereof of total annual cost of employment	R1 893	Commensurate with Level 12, 13, 14 salary bands.
2a. Salaried Staff	Associates and managers		17.5% per R100.00 or part thereof of total annual cost of employment	R1 350	Commensurate with Level 11, 12, 13 salary bands
2b. Salaried Staff	Registered architectural professionals performing work of an architectural nature and carrying direct responsibilities for activities related to a project.		16.5% per R100.00 or part thereof of total annual cost of employment	R913	Commensurate with Level 9, 10, 11, 12 salary bands



South African Council
for the Architectural Profession

51 Wessel Road, Right Wing,
Rivonia, Sandton, 2128

P.O. Box 1500, Rivonia, 2128

Tel: 011 479 5000 | Fax: 011 479 5100

Email: info@sacapsa.com
Web: www.sacapsa.com

2c. Staff	Salaried	Registered architectural professionals performing work of an architectural nature under direction and control.	15% per R 100.00 or part thereof of total annual cost of employment	R543	Commensurate with Level 7, 8, 9, 10 salary bands
2d. Staff	Salaried	Staff performing work under direction and control to support architectural work outputs.	12.5% per R100.00 or part thereof of total annual cost of employment	R388	Commensurate with Level 6, 7, 8 salary bands

3.3. Due to the Client having to relocate to a difference Province due to his work task, he has requested that you provide your full architectural fees based on Project Cost Based Fee. The budget remains at R2 500 000-00.

3.3. 1	<p>You are asked to present a project cost-based fee for your service.</p> <p>Ensure your offer will be in line with the current SACAP professional fee guideline</p> <p>Calculate your total professional fees for the project.</p> <p>(Board Notice 471 of 2023). The table below offers the SACAP Guideline:</p>	(7)
3.3. 2	<p>Calculate each work stage.</p> <p>This must include the minimum fees for all the stages from Stage 1 to Stage 6.</p> <p>Include VAT at 15%</p>	(14)



South African Council
for the Architectural Profession

51 Wessel Road, Right Wing,
Rivonia, Sandton, 2128

P.O. Box 1500, Rivonia, 2128

Tel: 011 479 5000 | Fax: 011 479 5100

Email: info@sacapsa.com
Web: www.sacapsa.com

Table 1: Low Complexity

LOW COMPLEXITY					
Cost Bracket	Value of works		Primary Fee	Plus, secondary fee	
	From	To		Add %	On balance over
	A	B	C	D	E
1.	1	200 000,00	11 341,85	17,53%	1
2.	200 001,00	650 000,00	46 393,33	16,85%	200 001,00
3.	650 001,00	2 000 000,00	122 193,97	12,43%	650 001,00
4.	2 000 001,00	4 000 000,00	289 927,74	10,83%	2 000 001,00
5.	4 000 001,00	6 500 000,00	506 559,80	10,55%	4 000 001,00
6.	6 500 001,00	13 000 000,00	770 251,28	9,16%	6 500 001,00
7.	13 000 001,00	40 000 000,00	1 365 321,64	8,86%	13 000 001,00
8.	40 000 001,00	130 000 000,00	3 755 421,23	8,85%	40 000 001,00
9.	130 000 001,00	260 000 000,00	11 717 437,86	8,28%	130 000 001,00
10.	260 000 001,00	520 000 000,00	22 475 739,42	8,08%	260 000 001,00
11.	520 000 001,00	1 040 000 000,00	43 501 431,14	7,88%	520 000 001,00
12.	1 040 000 001,00	0	84 483 711,59	7,28%	1 040 000 001,00

QUESTION 4 - UNDERSTANDING CONTRACTS

24 marks

You have been working for a practice that creates bespoke architectural contracts, generated with the help of Artificial Intelligence (AI). Help them to gain a better understanding of its benefits and disadvantages of this by answering the questions below:

4.1	4.1 Of what benefit does the PROCSA Client/Consultant Professional Service Agreement have over a bespoke contract? (8)	(8)
4.2	Consider each of the following statements regarding the services of an architectural professional and indicate whether or not they will constitute a contractual obligation to the client. Provide a motivation for each.	
1.	1. The drawings and documentation for the project will be free of mistakes.	(3)
2.	The quality of the building will be guaranteed. (3)	(3)
3.	The service will be provided with reasonable professional skill, care and diligence. (3)	(3)
4.3	4.3 Intellectual property copyrights have recently been a widely discussed topic with the advent of Generative Artificial Intelligence (GenAI). Provide the definition of 'copyright' as it relates to the work of an architectural professional.	(3)

Council President: Mr C Nduku. **Council Vice President:** Ms L Shongwe.

Council Members: Mr R Vuzane CA (SA); Ms M Pepeta; Mr K Bingham; Dr J Mirembe; Mr V Phailane; Ms K Cupido; Ms S Bongela; Mr L Nematswerani; Mr D Basdew.

Registrar: Advocate T Fiduli



South African Council
for the Architectural Profession

51 Wessel Road, Right Wing,
Rivonia, Sandton, 2128

P.O. Box 1500, Rivonia, 2128

Tel: 011 479 5000 | Fax: 011 479 5100

Email: info@sacapsa.com
Web: www.sacapsa.com

4.4	Provide an example of what would be regarded as a breach of the copyright of an architectural professional.	(4)

QUESTION 5 - CODE OF CONDUCT AND PRACTICING ARCHITECTURE AS AN ENTITY in REAL WORLD APPLICATIONS 22 marks

A friend approaches you on starting a new business in South Africa. Looking for guidance, she turns to you to answer the following questions:

5.1.	5.1.1.	What is the simplest type of business entity in South Africa which can be run by a singular person?	(2)
	5.1.2.	2. What is the minimum number of people permitted to engage in a Partnership?	(2)
	5.1.3.	3. Which type of business entity can no longer be newly established in South Africa?	(2)
	5.1.4.	4. Which type of business entity has shareholders as participants?	(2)

5.2. You are the principal agent on a large housing project. The contractor's site agent is not proceeding diligently and fails to carry on with the works as per the approved work program.

After a site meeting with the contractor, site agent and other consultants on the project, the employer was not present at the meeting; you all agreed that the contractor should be put on terms. To this end, you, as the principal agent, write a letter to the contractor instructing him that the site agent should be replaced and that the work as per the program should be attended to urgently.



The detailed instructions indicate that a new site agent should be appointed and the surface bed should be completed within two weeks. The letter, written on your letterhead, was emailed to the contractor and copied to the employer, end-user representative and other consultants on the project. The end-user representative responds to the instruction, giving you reasons why your letter was out of place and 'instructs' you to retract the letter.

5.2.1. How would you respond to this scenario?

(5)

5.3. Your friend has also recently become aware of the monthly average salary earnings in South Africa. For each year, he tabulates them as follows (On right, salary in ZAR):

2023	26,817
------	--------

2024	27,450
------	--------

He realises that his total revenue projected for the year is not able to afford the average national salary per month.

5.3. He approaches you with a question on how to reduce expenses in the business, so income can increase. What would you suggest can be done to minimise expenses in the architectural firm? List 5 (five)

(5)

5.4. After a long discussion, he comes to the conclusion that it may be best to make you a partner in the business. You advise him that you can become a partner immediately as a Candidate.

(4)

Explain why this is not the correct method to becoming a partner and advise what needs to be done.



QUESTION 6 - UNDERSTANDING TECHNOLOGICAL DEVELOPMENTS AND ITS IMPACT ON RUNNING A PRACTICE 10 marks

<p>6.</p>	<p>STATISTICS SOUTH AFRICA 9 P0021</p> <p>Figure 4 – Time series of turnover per industry from 2001 to 2023</p> <p>Turnover (R billion)</p> <p>SIC 1 SIC 4 SIC 5 SIC 9</p> <p>SIC 1 - Forestry and fishing SIC 4 - Electricity, gas and water supply SIC 5 - Construction SIC 9 - Community, social and personal services (excluding general government and educational institutions)</p>	
	<p>The previous economic downturn post 2010 (see above) created an unfavourable scenario for the industry which led to your employer being retrenched and opening her own successful architectural business.</p> <p>As a resilient business owner, she finds herself in the position of having to prepare for such an event once again. She informs you staff of the challenging times ahead, and decide to include everyone in the process of brainstorming a way forward.</p> <p>You are invited to contribute ideas. You are advised to look at the opportunities which exist now which did not exist 15 years ago when the business opened up,</p>	
<p>6.1</p>	<p>State which technologies have the most likely industry application, which can greatly benefit the operation of your company. Name 3 (three): (3)</p>	<p>(6)</p>
<p>6.2</p>	<p>State how two (2) of these technologies are able to open up new revenue streams for the firm</p>	<p>(4)</p>

QUESTION 7 – REVIEW OF ARCHITECTURAL DRAWINGS 18 marks



In light of the recent flooding in the KZN region, a contractor reaches out to you provide guidance on SANS applications on a site he is working on. He would like to know more the correct interpretation of specific sections in the document.

Select the correct answer from the Multiple Choice Questions Below to help clarify his questions.

7.1 7.1. Figure 1 indicates a sectional view of a Ventilated Improved Pit (VIP) Toilet according to SANS 10400 Part Q.

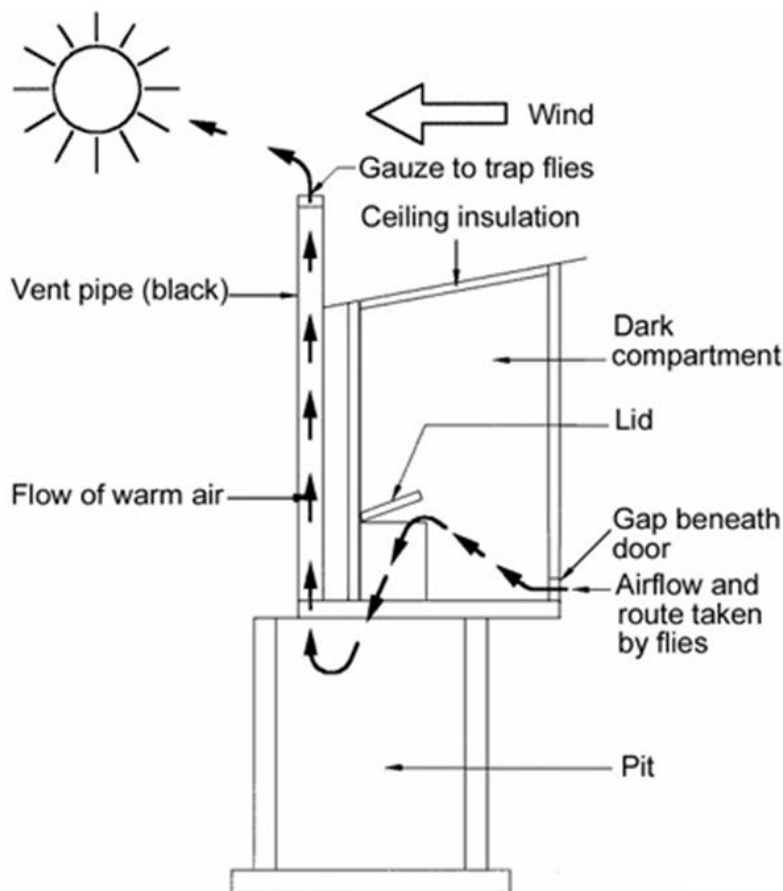
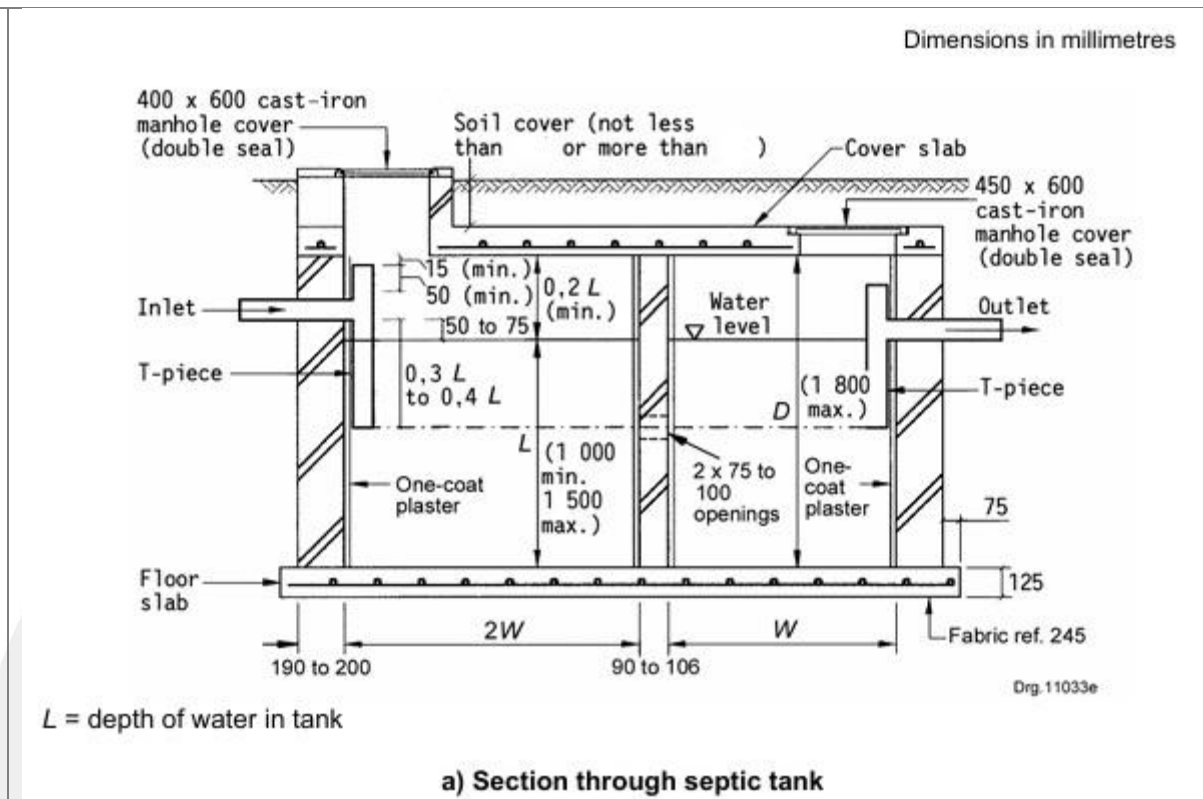

Figure 1: Ventilated Improved Pit (VIP) Toilet

1. In which direction should the door to the VIP toilet face to ensure optimal ventilation? (2)
- a) North or East
 - b) West or South
 - c) East or North
 - d) South or North

7.2 Fig 2 indicates a sectional view of a typical septic tank in accordance with SANS 10400 Part P.



7.2. Fig 2 indicates a sectional view of a typical septic tank in accordance with SANS 10400 Part P. (2)

The soil cover should not be less than mm or more thanmm. (2)

- a). Not less than 50 mm and not more than 1000 mm
- b). Not less than 200 mm and not more than 1500 mm
- c). Not less than 150 mm and not more than 300 mm
- d). Not less than 10 mm and not more than 500 mm



7.3 Fig 5 indicates a sectional view of a typical septic tank in accordance with SANS 10400 Part P.

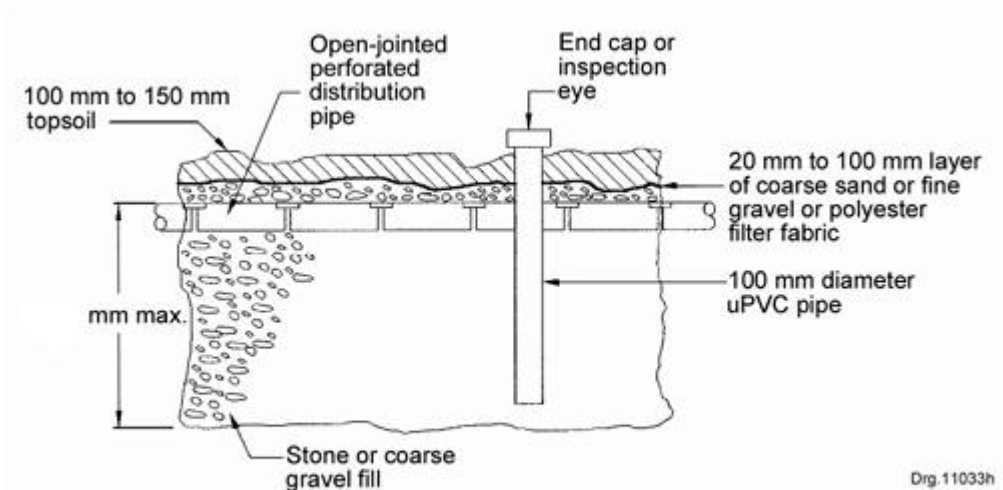

a) Longitudinal section

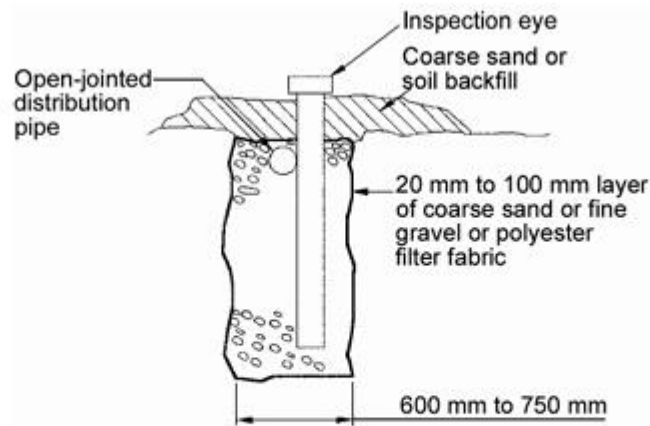

b) Cross section

Figure 5 — Detail of french drain construction

The soil cover should not be less than mm or more thanmm.

- a). 1000 mm max
- b). 1200 mm max
- c) 1800 mm max
- d) 2500 mm max

(2)

